

HRB SHLW ROAD BLOCKER

(Anti-terror / Heavy Duty - Shallow Mount Model)

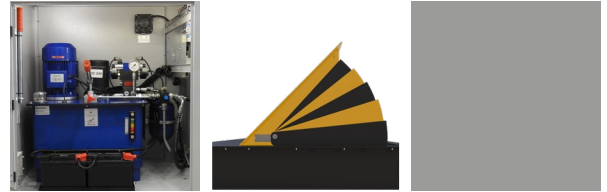

PAS 68 (N3)
IWA 14 (N3C)
ASTM F2656 (C750)



Power	Standard 380V AC 3-Phase 50/60 Hz, 2,2 - 11 kW motor (varies depending on blocker size). Operating with 24V DC in case of power failure is optionally available.
Control Pack	24V DC powered PLC control unit is placed in power unit cabinet. 24V DC (opt.12V DC / 220V AC) solenoids.
Speed	Standard operation ~2 - 4 sec. (ascend/descend) depending on road blocker dimensions. Not less than 300 cycles per hour Fast raise up (EFO, by optional hydraulic accumulator) approximately 1,5 sec. depending on road blocker dimensions.
IP Rating	IP55 - Hydraulic Power Unit (optionally electronics control unit with IP67 protection box) IP68 - Hydraulic Piston
Operating Temperature	-25°C / +70°C
Crash / Impact Rating	Crash tested and certified according to: IWA 14-1:2013 Road Blocker V/7200[N3C]/80, PAS68:2013 Road Blocker V/7500[N3]/80, and ASTM F2656-18 C750/7200 standards (HRB 30 P 90 SHLW model).

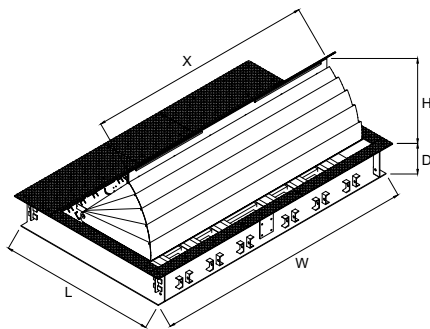

Product Code	Mounting Depth 400 mm	Nr. of Pistons	Raising Height (H) 1000 mm
	Blocker Unit Width - mm (X)		Dimensions - mm (LxWxD)
HRB 20P 100 SHLW	2000	1	2270 x 2490 x 400
HRB 25P 100 SHLW	2500	1	2270 x 2990 x 400
HRB 30P 100 SHLW	3000	1	2270 x 3490 x 400
HRB 35P 100 SHLW	3500	2	2270 x 3990 x 400
HRB 40P 100 SHLW	4000	2	2270 x 4490 x 400
HRB 45P 100 SHLW	4500	2	2270 x 4990 x 400
HRB 50P 100 SHLW	5000	2	2270 x 5490 x 400
HRB 55P 100 SHLW	5500	2	2270 x 5990 x 400
HRB 60P 100 SHLW	6000	2	2270 x 6490 x 400

* Different raising heights are optionally available.

Axle Load Resistance	50 t
Hydraulic Cylinder Unit	Dust sealed hydraulic cylinder, developed for heavy duty use. 2 - 3 m wide models contain single piston. 3,5 - 6,0 m wide models contain double pistons. Contains safety valve for hose bursts.
Hydraulic Power Unit and Cabinet	Strengthened industrial hydraulic pump. S1 heavy-duty motor. 40 - 120 lt capacity oil tank with magnetic metal collector and suction filter. Built-in oil level indicator and sensor, oil temperature indicator and audio alarm feature for low oil level, hygrothermostat controlled. Standard 70 - 150 bar pressure (max. 180 bar). Up to 40 m R2 type (double wire braided mesh) reinforced hydraulic hose between HPU and Road Blocker.



HRB SHLW ROAD BLOCKER

(Anti-terror / Heavy Duty - Shallow Mount Model)

Motor, hydraulic pump and solenoid valves are placed in an easily accessible galvanized and electrostatic powder coated steel cabinet with 2 built-in lock lids (opt. stainless steel cabinet).

Cabinet Type	Width (mm)	Length (mm)	Height (mm)
Cabinet 1	940	570	970
Cabinet 2	1040	590	1285
Cabinet 3	1243	840	1285

*Suitable cabinet type is selected according to the preferred product configuration.

System
Down, up, stop, emergency inputs and external sensor inputs/outputs (e.g. loop detector, safety sensor, traffic light, remote control, etc.). System alerts with an audio signal during lowering and raising operation. A loud siren alert in case of alarm or emergency. System stops in case of emergency as per default set-up and possible to be lowered or raised automatically (user's preference). Can be lowered and raised manually in case of power failure or during maintenance with manual pump and manual valve feature. Automatic raise up mode deploys (available with optional loop detector) the road blocker after the vehicle has passed over. Sensor controlled stopping both at the top and bottom positions of the blocker unit. Free standing piston connection structure that does not put any load on the piston during vehicle passage and in case of an impact. Safety devices (if any, such as; safety sensor, loop detector, etc) are enabled in case fast raise up (EFO, optional) feature is activated and they can be optionally disabled.

Blocker Unit (Underground Unit)
All parts are coloured with industrial paint with two components over anticorrosive primer application. Body is structured and strengthened with U-shaped beams. Product is designed that no vehicle crashing effect can displace it after embedded or installed in to the ground.

Blocker Unit (Impact Blocking Unit)
Top plates (vehicle pass through surface) are hot dip galvanised and electrostatic powder coated. All other parts are coloured with industrial paint with two components over anticorrosive primer application. Moving parts are colored with RAL 1003 yellow (impact surface yellow-black) and fixed road surface plates in RAL 9005 black. In addition, the impact surface is finished with reflective signs and warnings. Bulge free hidden hinge structure below the ground level allows vehicles to pass over smoothly and quietly. Top panels where the vehicles pass over are made of 10/11 mm thick hot-dip galvanized steel with non-skid surface. The road blocker moves up and down as a block supported by Ø60 mm steel hinges at pivot points, which are welded on the main frame with wedges for extra strength. Number of hinges varies according to blocker width (3 m wide blocker contains 8 pieces of hinges). Impact blocker unit raises with 45° angle from the ground level. Impact blocking unit and the underground unit are connected with 6 sets (in 3 m long road blocker, varies according to road blocker width) of linkages in 2 pairs of 15 mm each fastened together by stainless steel shafts of 40 mm diameter. When the blocker is in the raised position, impacts are distributed to the linkages and also it is designed so that the vertical impact power distribution panels are designed to absorb the impact by transmitting the impact energy to the ground. The 10 mm thick impact surface strength is increased by the impact power distribution panels and the U-shaped beams connecting these panels together behind it. Front and side faces of the blocker unit are covered with decorative telescopic panels (opt.). A top lid integration is available for easy access to interior units for service and maintenance purposes.

Control System
3 buttons for up, down and stop operations and 1 button for emergency stop are contained in a box that is suitable for outdoor use (optionally, 1 button for EFO-fast raise up). System stops its movement with the command from safety sensor (opt.) and loop detectors (opt.). Contains built-in LED indicators and 10 m cable. The system works with PLC as standard. Status of safety sensors (if any) and loop detectors (if any), position and movement of the blocker and low oil level situation of the system can be monitored with optional PLC with diagnostic display. Compatible with any access control system (by third parties).



Power-off Situation
Road Blocker remains in its position in case of power-off. As default, 3 full-cycle movement is available.

Optional Features and Accessories
Telescopic front panels, hydraulic accumulator for EFO-fast raise up (1 piston or 2 pistons systems), 24V DC motor in case of power failure (50 deploy + 50 retract), oil heater (for oil tank), oil cooler, heater for electronic components, submersible pump, traffic light (Ø200/300 mm, red-green LED, electrostatic powder coated over 304 grade stainless steel body), traffic light pole (electrostatic powder coated over hot dip galvanised steel), loop detector (double contact), safety sensors (with 50 cm height poles), IP67 box (for PLC, SMPS, connectors etc inside power unit), wireless remote control (receiver and transmitter), external buttons, hot dip galvanization, double effect hydraulic unit, double speed hydraulic unit, PLC with diagnostic display, front flashing indicators, different product dimensions.

Installation
Installation with C30 grade concrete and steel rebar reinforcement. Ground levelling and preparation works shall be carried on before pouring the concrete. Allowable bearing value of the ground shall be minimum 1/2 kg/cm², if not, works shall be carried on to fulfil. Installation shall be done according to the manufacturer's instructions.

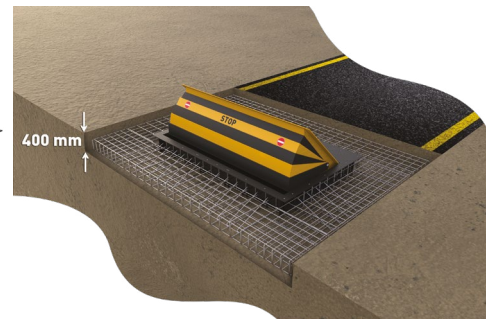
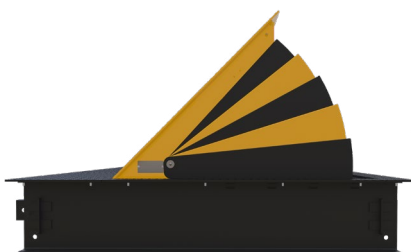

*Design and specifications are subject to change without notice.

Hydraulic Unit Structure

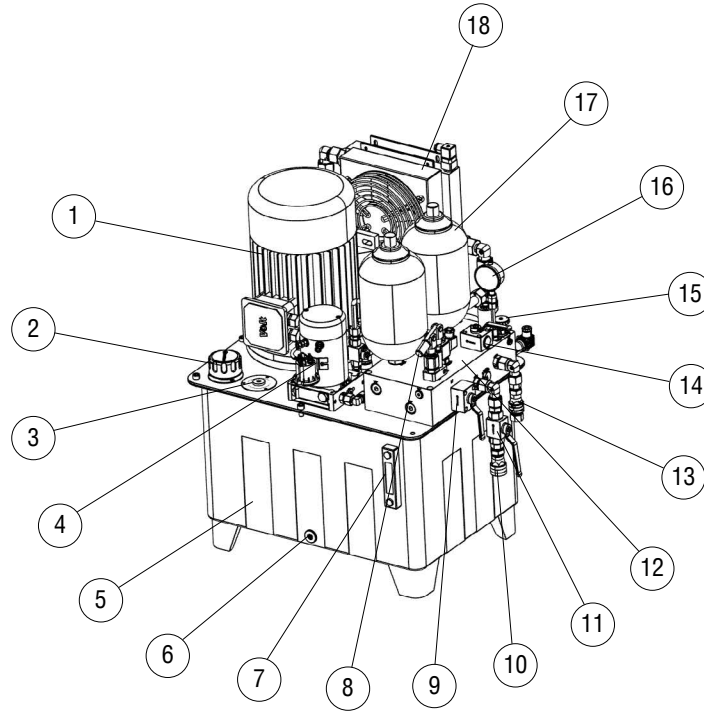

- | | |
|---|---------------------------------------|
| 1 - Electric motor | 9 - Manual pump active/passive valve |
| 2 - Oil filling cap | 10 - Line A quick coupling |
| 3 - Oil Level Sensor | 11 - Line A valve |
| 4 - 24 V DC motor | 12 - Hydraulic main block |
| 5 - Oil Tank | 13 - Line B quick coupling |
| 6 - Oil discharge cap | 14 - Manual lowering valve |
| 7 - Oil level and temperature indicator | 15 - Speed adjustment valve (Descend) |
| 8 - Manual pump | 16 - System pressure gauge |
| 9 - Manual pump active/passive valve | 17 - Hydraulic accumulator |
| | 18 - Oil cooler |

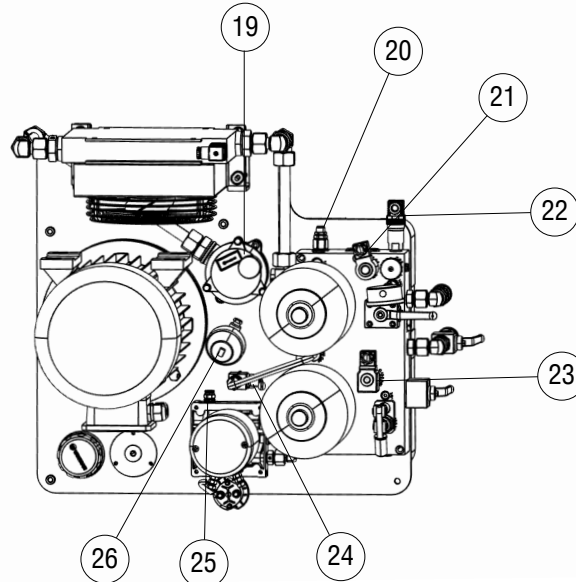

- | |
|--|
| 19 - Oil return filtre |
| 20 - Safety valve |
| 21 - Solenoid valve (Descend) |
| 22 - Pressure sensor |
| 23 - Hydraulic accumulator solenoid valve |
| 24 - Hydraulic accumulator discharge valve |
| 25 - DC motor safety valve |
| 26 - Oil temperature sensor |